

MASS: 6565 kg.

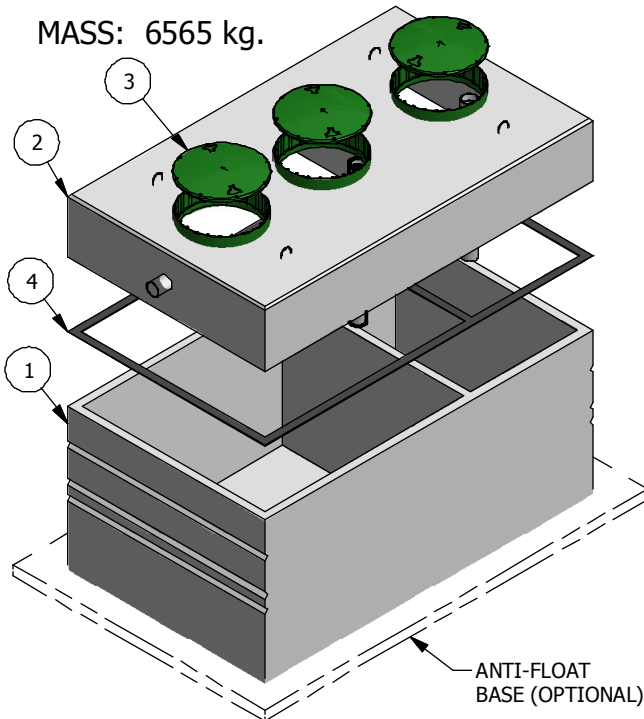

NOTES

- PRODUCT MANUFACTURED IN ACCORDANCE WITH CSA B66
- MINIMUM CONCRETE STRENGTH AT 28 DAYS: 32 MPA
- MAX WATER CEMENT RATIO OF 0.45 & AIR CONTENT OF 5-8%
- WWM IN ACCORDANCE TO ASTM A1064
- GRADE 400 REBAR REINFORCEMENT
- HARD STEEL FINISH
- 23.53 IGal/in (42.11 l/cm)

#	DESCRIPTION	ITEM #	KG
1	1500 IGAL SEPTIC TANK BASE	14756	4152
2	1500 IGAL SEPTIC TANK LID	14755	2413
3	POLYLOK RISER COVER Ø24"	20545	
4	CONSEAL CS-102	20405	
5	RIGID PVC PIPING 4" SCH40		

FRASERWAY PRECAST LTD

WWW.FRASERWAYPRECAST.COM

604-534-2911

**1500 IGal [6820 l] SEPTIC TANK
2 CHAMBER**

SIZE	DRAWING #	14755	REV	SHEET
A	1500G ST			1/1