

#	PART #	DESCRIPTION	CODE	KG
1	DW1200 B	DRYWELL Ø1200 EXTENDED BASE	12881	1078
2	DW1200x.9	DRYWELL Ø1200 x 100 HOLES	12859	759
3	DW1200 R.9	DRYWELL Ø1200 x 900 RISER	12854	897
4	DW1200 R.6	DRYWELL Ø1200 x 600 RISER	12849	595
5	DW1200 R.3	DRYWELL Ø1200 x 300 RISER	12844	297
6	DW1200 L1	DRYWELL Ø1200 LID (TYPE 1)	12874	513
7	DW LC	Ø600 [24"] CONCRETE LID	12213	65

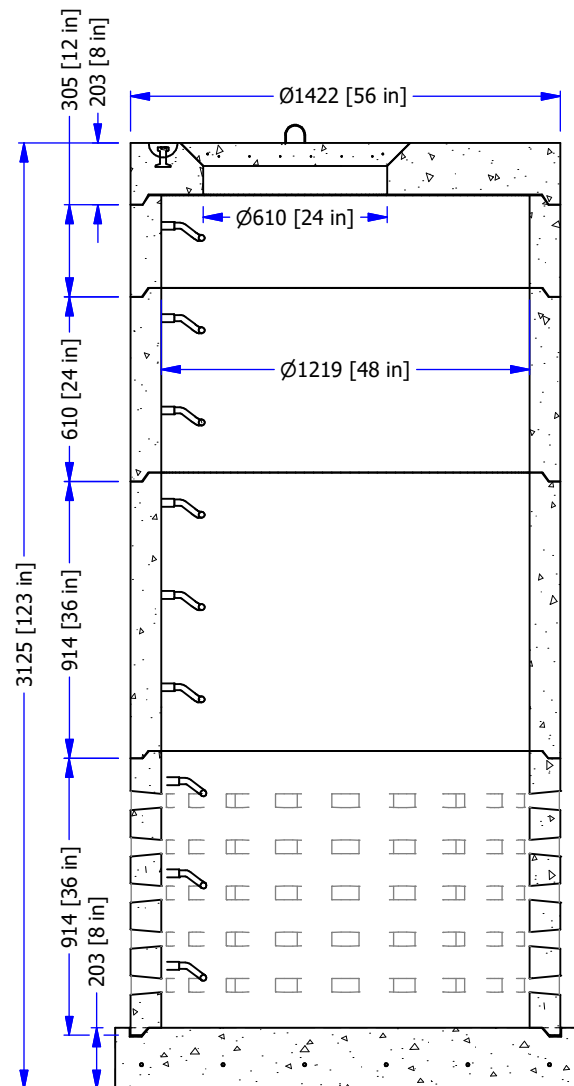
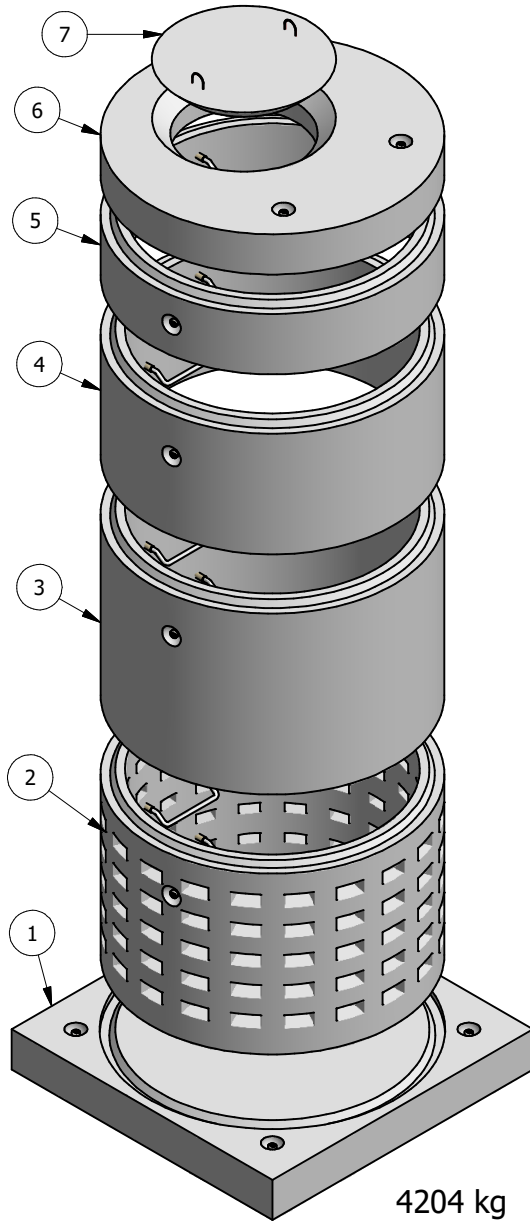
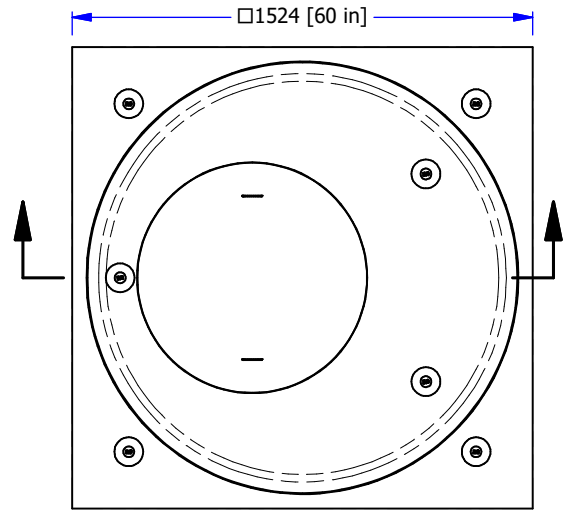

- MANUFACTURED IN ACCORDANCE WITH CSA A23.4
- MINIMUM CONCRETE STRENGTH AT 28 DAYS: 32 MPA
- REINFORCED WITH GRADE 400 REBAR
- WWM IN ACCORDANCE TO ASTM A1064
- HARD STEEL FINISH
- DESIGNED FOR BOULEVARD USE BCL625 H20 OCCASIONAL LOADING

WWW.FRASERWAYPREKAST.COM

(604) 534-2911



**FRASERWAY PREKAST LTD**  
A BMGROUP COMPANY

## DRYWELL Ø1200 [48"] w RISERS & TYPE 1 TAPERED CONCRETE LID

SIZE **A** DRAWING #

DW1200 EB R L

REV SHEET  
1/1