

#	PART #	DESCRIPTION	CODE #	KG
1	DW1200x.9	DRYWELL Ø1200 x 100 HOLES	12859	759
2	DW1200 IB	DRYWELL Ø1200 INTEGRAL BASE	12508	798
3	DW1200 R.9	DRYWELL Ø1200 x 900 RISER	12854	897
4	DW1200 R.6	DRYWELL Ø1200 x 600 RISER	12849	595
5	DW1200 R.3	DRYWELL Ø1200 x 300 RISER	12844	297
6	DW1200 L2	DRYWELL Ø1200 LID TYPE 2	12874	517
7	TR18 FRAME	CAST IRON FRAME TR18	17209	61
8	TR18 COVER	CAST IRON COVER TR18	17218	51

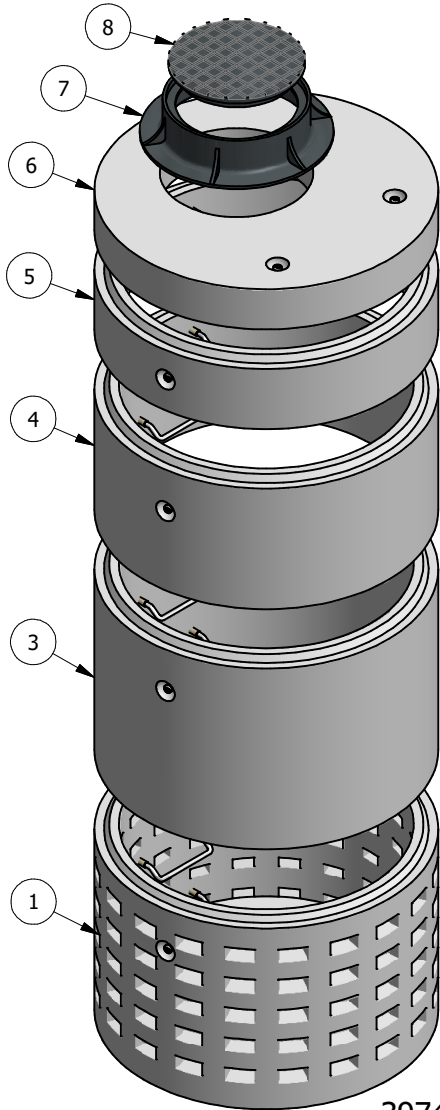

3974 kg

- MANUFACTURED IN ACCORDANCE WITH CSA A23.4
- MINIMUM CONCRETE STRENGTH AT 28 DAYS: 32 MPA
- REINFORCED WITH GRADE 400 REBAR
- WWM IN ACCORDANCE TO ASTM A1064
- HARD STEEL FINISH
- DESIGNED FOR ROADWAY USE BCL625 H20 LIVE LOADING

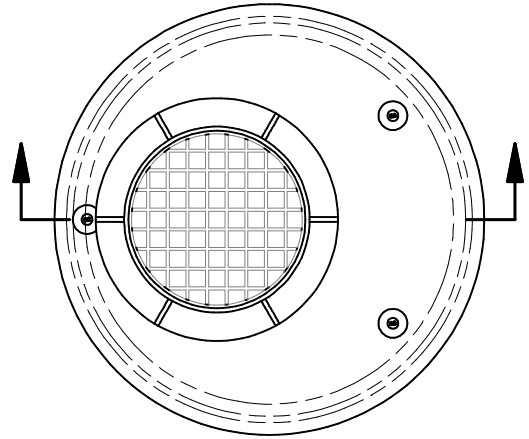
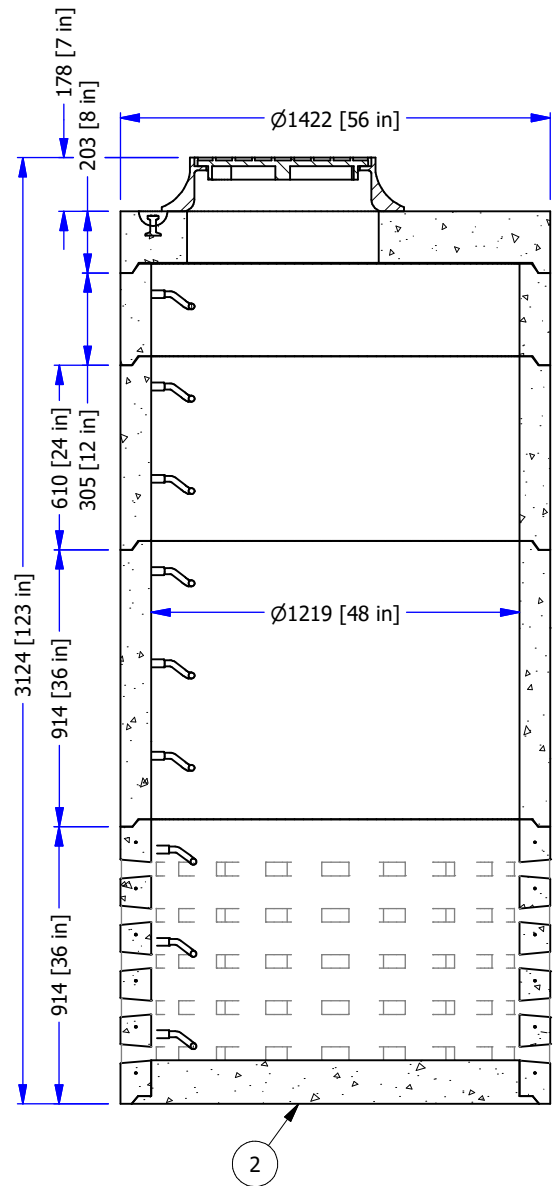

WWW.FRASERWAYPREKAST.COM

(604) 534-2911



**FRASERWAY PREKAST LTD**  
A BMGROUP COMPANY

## DRYWELL Ø1200 [48"] w RISERS & TYPE 2 MANHOLE ACCESS LID

SIZE  
A

DRAWING #

DW1200 B R MH

REV SHEET  
1/1