

WITHOUT LID

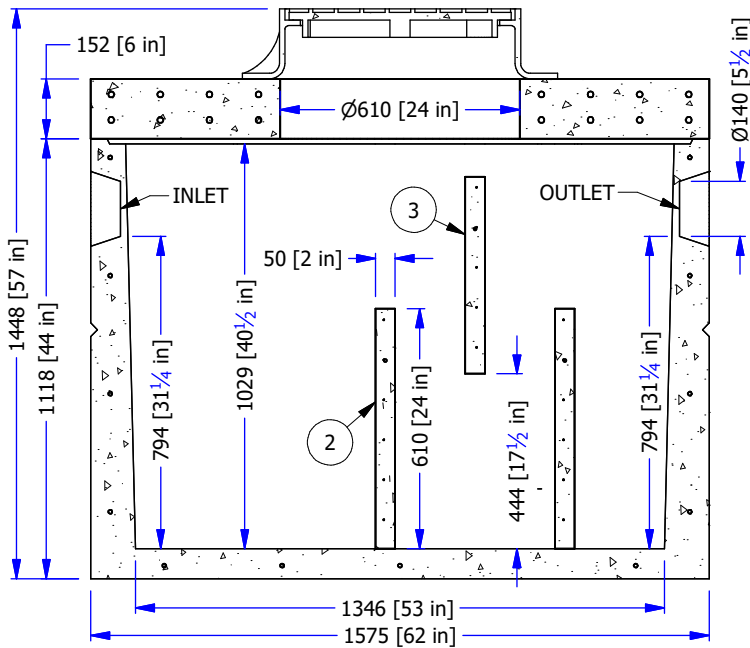

#	DESCRIPTION	ITEM #	KG
1	OI 110G BASE	16401	1290
2	BAFFLE WALL #1		43
3	BAFFLE WALL #2		36
4	OI 110G LID TYPE 1	16412	370
5	CAST IRON FRAME TR18	17209	61
6	CAST IRON COVER TR18	17218	51

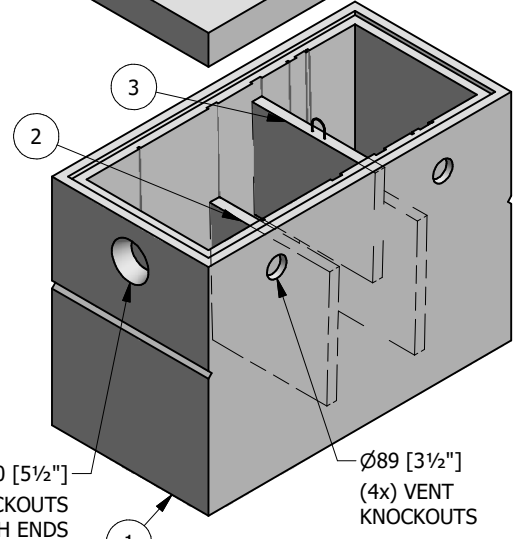
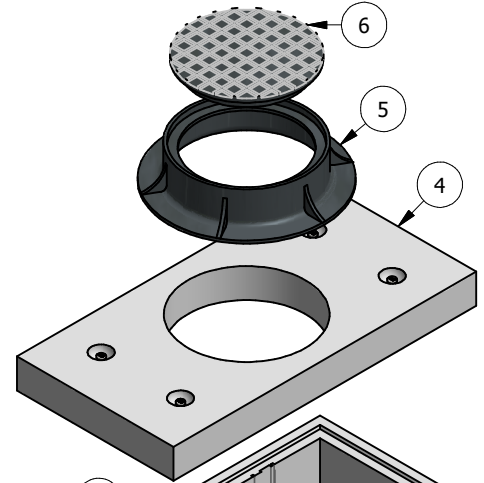

1894 kg

- PRODUCT MANUFACTURED IN ACCORDANCE WITH CSA 23.4
- CONCRETE STRENGTH @ 28 DAYS: 35 MPA MIN.
- H2O LOAD RATED
- REBAR: GRADE 400
- GASKET: CONSEAL CS-120
- MAXIMUM FLOW RATE: 50 LPM
- RETENTION TIME: 10 MINUTES
- TEMP OPERATING RANGE: 40 - 80°F / 4-27°C.
- BOUYANCY: 1627 kg
- SPECIFIC GRAVITY: OIL - 0.71 - 0.92
FRESH WATER - 1.00 - 1.03

WWW.FRASERWAYPREKAST.COM

(604) 534-2911

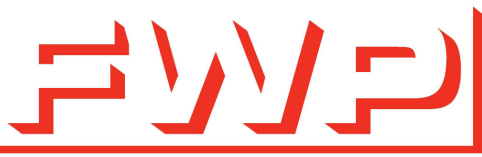

FRASERWAY PREKAST LTD
A BMGROUP COMPANY

OIL INTERCEPTOR 110 IGAL (500 I) STYLE I

SIZE DRAWING #

A

REV SHEET

OI 110G I

1/1