

#	DESCRIPTION	ITEM #	KG
5	CAST IRON LID TR18B	17218	49
4	CAST IRON FRAME TR18B	17209	72
3	OI 600G LID TYPE '2'	16454	1026
2	OI 600G BAFFLE		125
1	OI 600G BASE	16439	2241

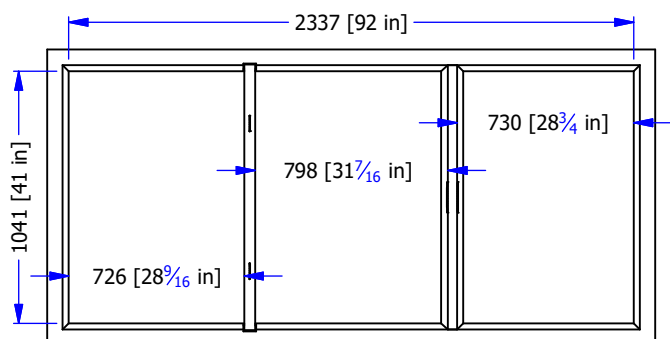

WITHOUT LID

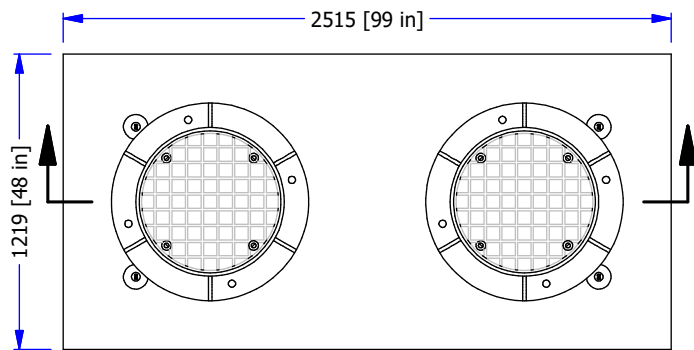
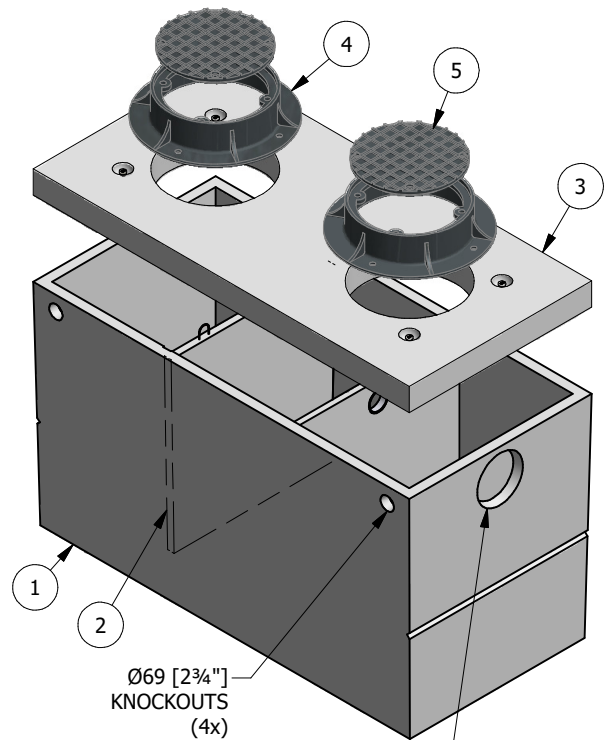
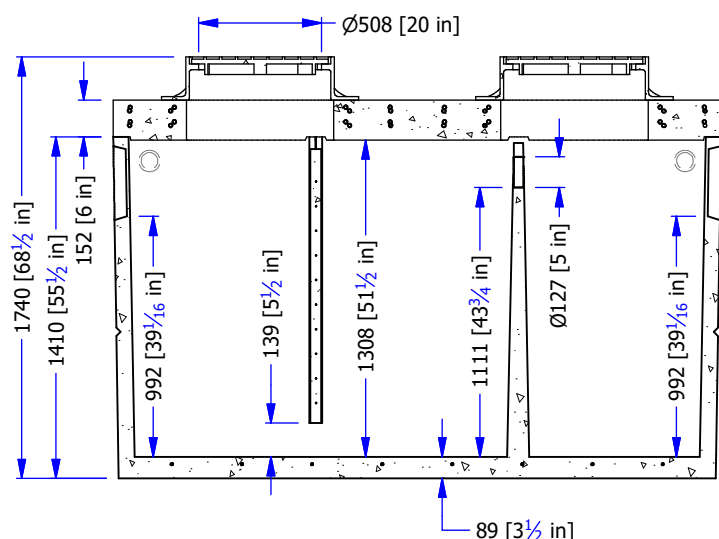

3635 kg

- MAXIMUM FLOW RATE: 270 LPM
- RETENTION TIME: 10 MINUTES
- BOUYANCY: 4485 kg
- TEMP OPERATING RANGE: 40 - 80°F / 4-27°C.
- SPECIFIC GRAVITY: OIL - 0.71 - 0.92  
FRESH WATER - 1.00 - 1.03

- MANUFACTURED IN ACCORDANCE WITH CSA 23.4
- CONCRETE STRENGTH @ 28 DAYS: 35 MPA MIN.
- H2O LOAD RATED
- REBAR: GRADE 400
- GASKET: CONSEAL CS-102
- USE IN NON-SULPHATE SOIL ONLY

WWW.FRASERWAYPREKAST.COM (604) 534-2911



OIL INTERCEPTOR 600 IGAL (2730 I)  
SLAB LID MANHOLE x2 (TYPE 2)

SIZE	DRAWING #	REV	SHEET
A			1/1
		OI 600G	