

#	DESCRIPTION	ITEM #	KG
1	1500 IGAL PUMP CHAMBER BASE		3640
2	1500 IGAL PUMP CHAMBER LID		2366
3	POLYLOK RISER COVER Ø24"	13530	1
4	CONSEAL CS-102	11695	3
5	RIGID PVC PIPING 4" SCH 40	12200	1

- MANUFACTURED IN ACCORDANCE WITH CSA B66
- MINIMUM CONCRETE STRENGTH AT 28 DAYS: 32 MPA
- MAX WATER CEMENT RATIO OF 0.45 & AIR CONTENT OF 5-8%
- WWM IN ACCORDANCE TO ASTM A1064
- GRADE 400 REBAR REINFORCEMENT
- HARD STEEL FINISH
- 23.53 IGal/in (42.12 l/cm)

WWW.FRASERWAYPREKAST.COM

(604) 534-2911

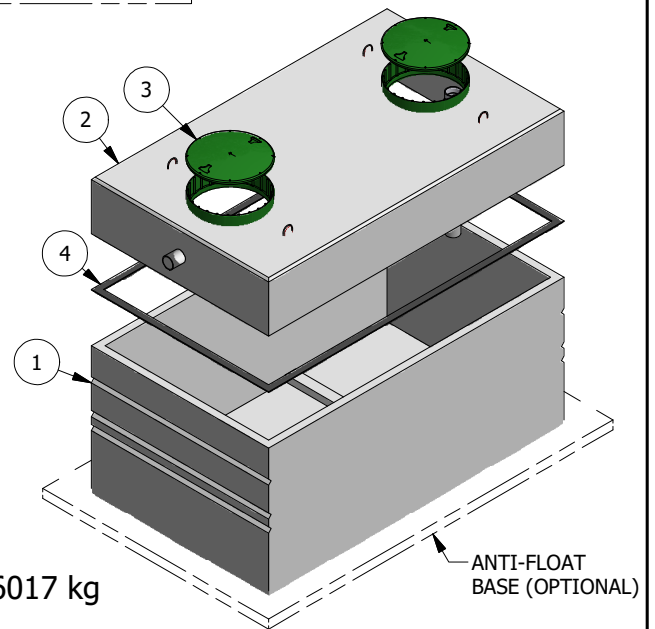

1500 IGal [6820 I] PUMP CHAMBER

SIZE A DRAWING #

13233

REV

SHEET

1500G PC

1/1