

#	DESCRIPTION	ITEM #	KG
1	DISTRIBUTION BOX 10 BASE	13606	81
2	DISTRIBUTION BOX 10 LID	13609	44
3	POLYLOK Ø12" COVER	12100	0
4	PAN HEAD SCREW #10 SQUARE HD		0
5	ROTOFLOW 3050-4"		0
6	ROTOFLOW 3050-3"		0

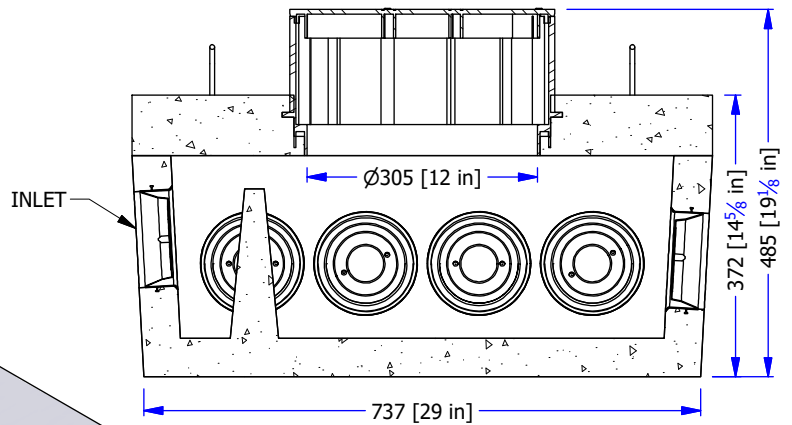
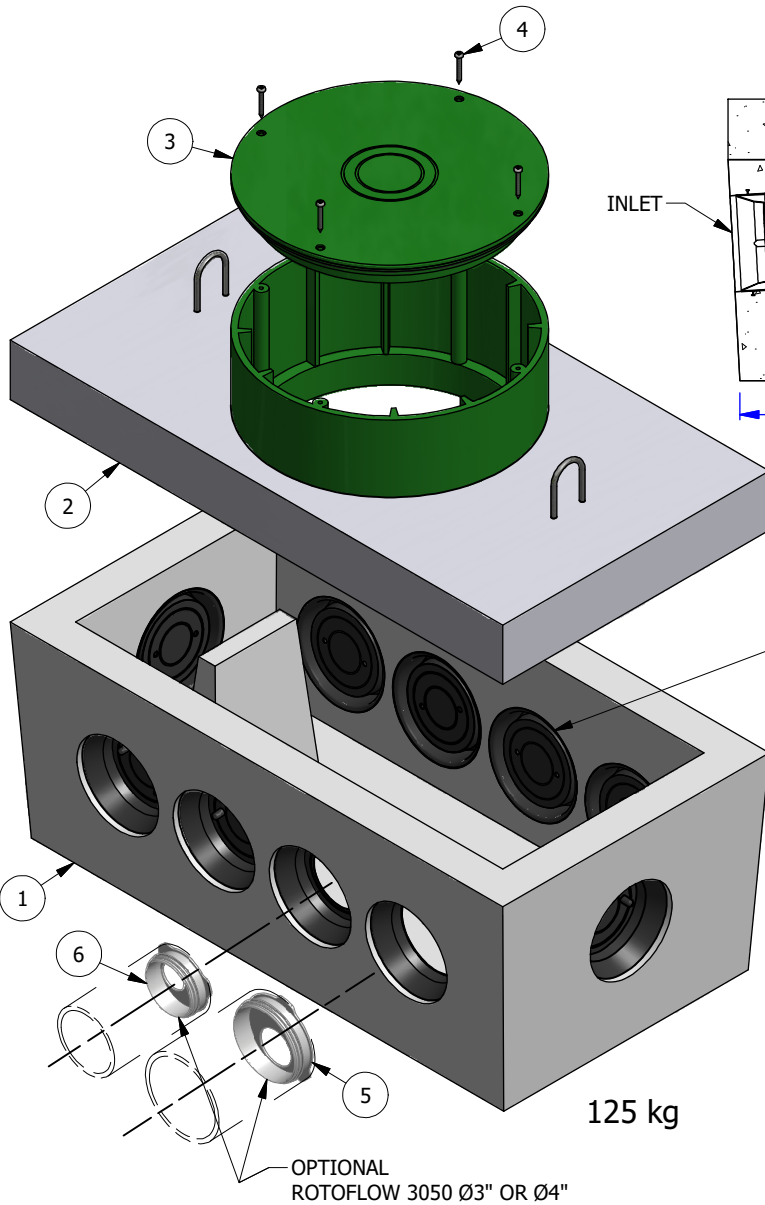
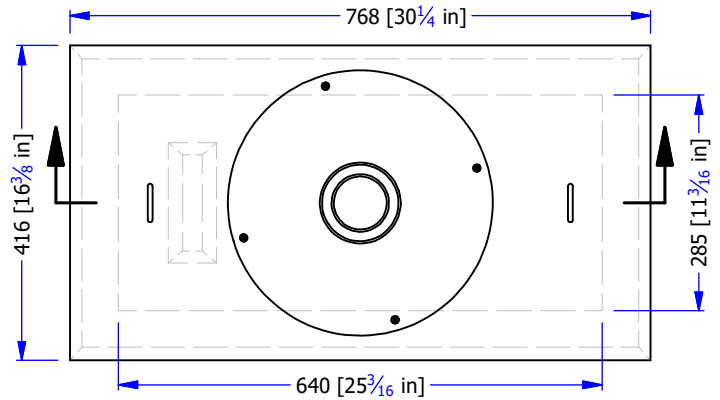

POLYLOK (8x)
 POLY I SEAL 3000
 TEAR OUTS
 FOR 2" sch40,
 3" SDR 35 or sch40,
 4" SDR 35 or sch40,
 or 4" CORRUGATED

125 kg

NOTES

- PRODUCT MANUFACTURED IN ACCORDANCE WITH CSA A23.4
- MINIMUM CONCRETE STRENGTH AT 28 DAYS: 32 MPA
- GRADE 400 REBAR REINFORCEMENT
- WWM IN ACCORDANCE TO ASTM A1064
- HARD STEEL FINISH

WWW.FRASERWAYPREKAST.COM

(604) 534-2911



FRASERWAY PREKAST LTD
 A BMGROUP COMPANY

DISTRIBUTION BOX 10 HOLE

SIZE A DRAWING #

14795

REV

SHEET

DB 10

1/1